

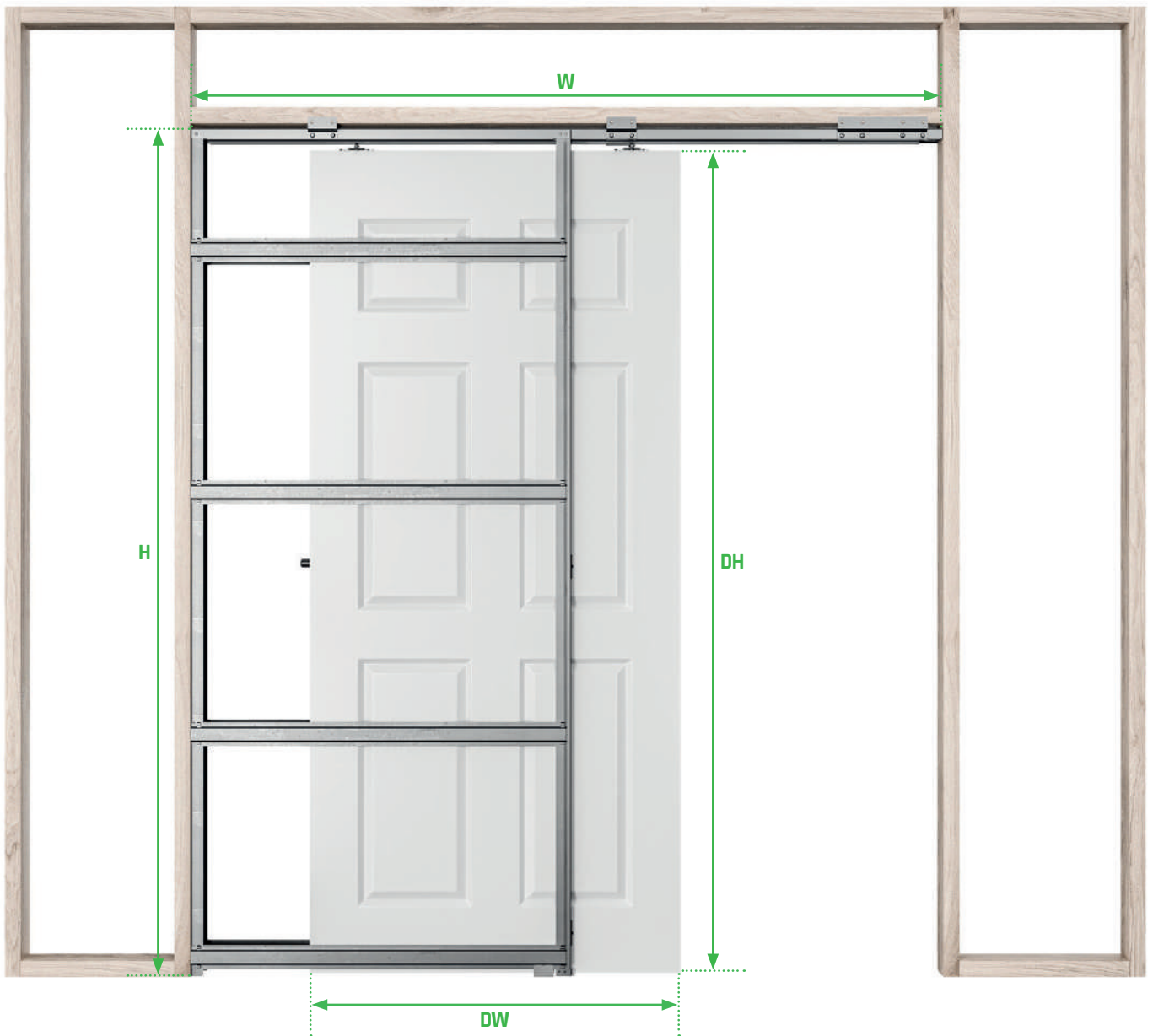

# Rocket Door Frames



- Install at finished floor level.  
*Instalar a nivel del suelo terminado*
- To obtain a sliding pocket door with two leaves it's necessary to join n°2 single door kits. (P.8)  
*Para obtener una puerta doble hay que juntar dos sistemas (p.8)*
- See page 4 for stud dimensions  
*Véase la página 4 para las dimensiones*

DOOR PANEL <i>PANEL PUERTA</i>		STUD <i>MONTANTES</i>	OVERALL DIMENSIONS <i>MEDIDA TOTAL</i>			
DW	DH		SINGLE DOOR <i>PUERTA ÚNICA</i>		DOUBLE DOOR <i>PUERTA DOBLE</i>	
			W	H	W	H
28"	80"	2x4	56" 1/4	82" 7/8	112" 5/8	82" 7/8
30"	80"	2x4	60" 3/8	82" 7/8	120" 3/4	82" 7/8
32"	80"	2x4	64" 3/8	82" 7/8	128" 3/4	82" 7/8
34"	80"	2x4	68" 3/8	82" 7/8	136" 3/4	82" 7/8
36"	80"	2x4	72" 1/4	82" 7/8	144" 1/2	82" 7/8

**Door Thickness** (*Espesor de la puerta*): 1" 3/8 - 1" 3/4



**CAUTION**  
ATENCIÓN

Please follow the instructions carefully as they have been designed to help you, don't skip any pages or stages as you may cause yourself problems. Use the correct tools and relevant protective clothing/eyewear, gloves are essential as there may be some sharp edges. A pair of trestles would be useful for the assembly.

*Por favor, siga las instrucciones cuidadosamente ya que han sido diseñadas para ayudarle, no se salte ninguna página o etapa. Utilice las herramientas correctas y la ropa/gafas de protección pertinentes, los guantes son esenciales ya que puede haber algunos bordes afilados. Un par de caballetes serían útiles para el montaje..*

**WANT TO SEE  
HOW IT'S DONE?**



**GO TO [WWW.ROCKETDOORFRAMES.COM](http://WWW.ROCKETDOORFRAMES.COM)  
TO SEE THE INSTALLATION VIDEO**

**TOOLS REQUIRED**  
HERRAMIENTAS NECESARIAS

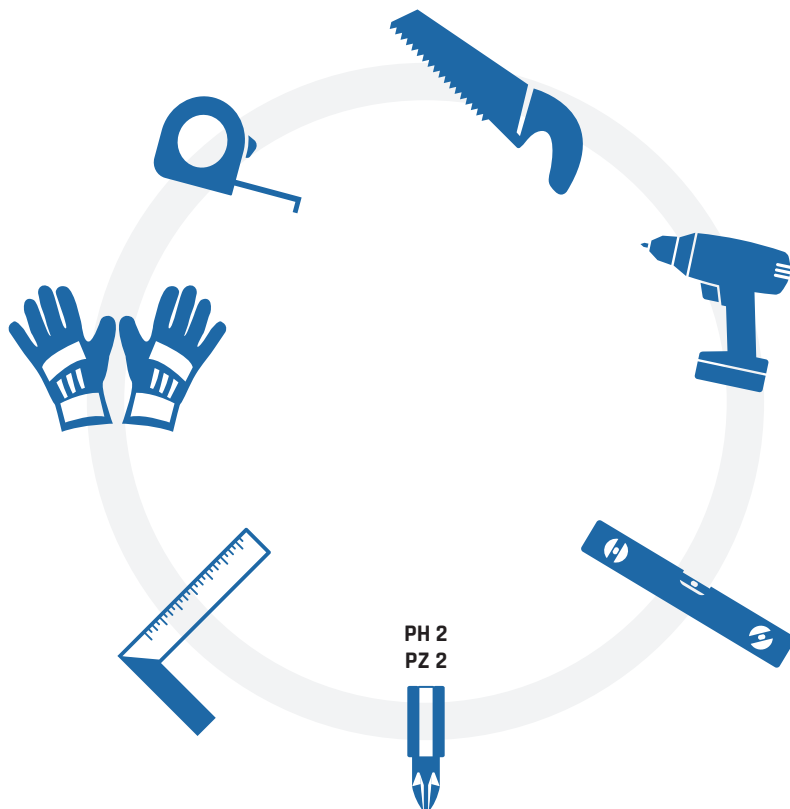

# CONTENTS

CONTENIDO

EACH KIT CONTAINS:  
QUE CONTIENE CADA KIT:

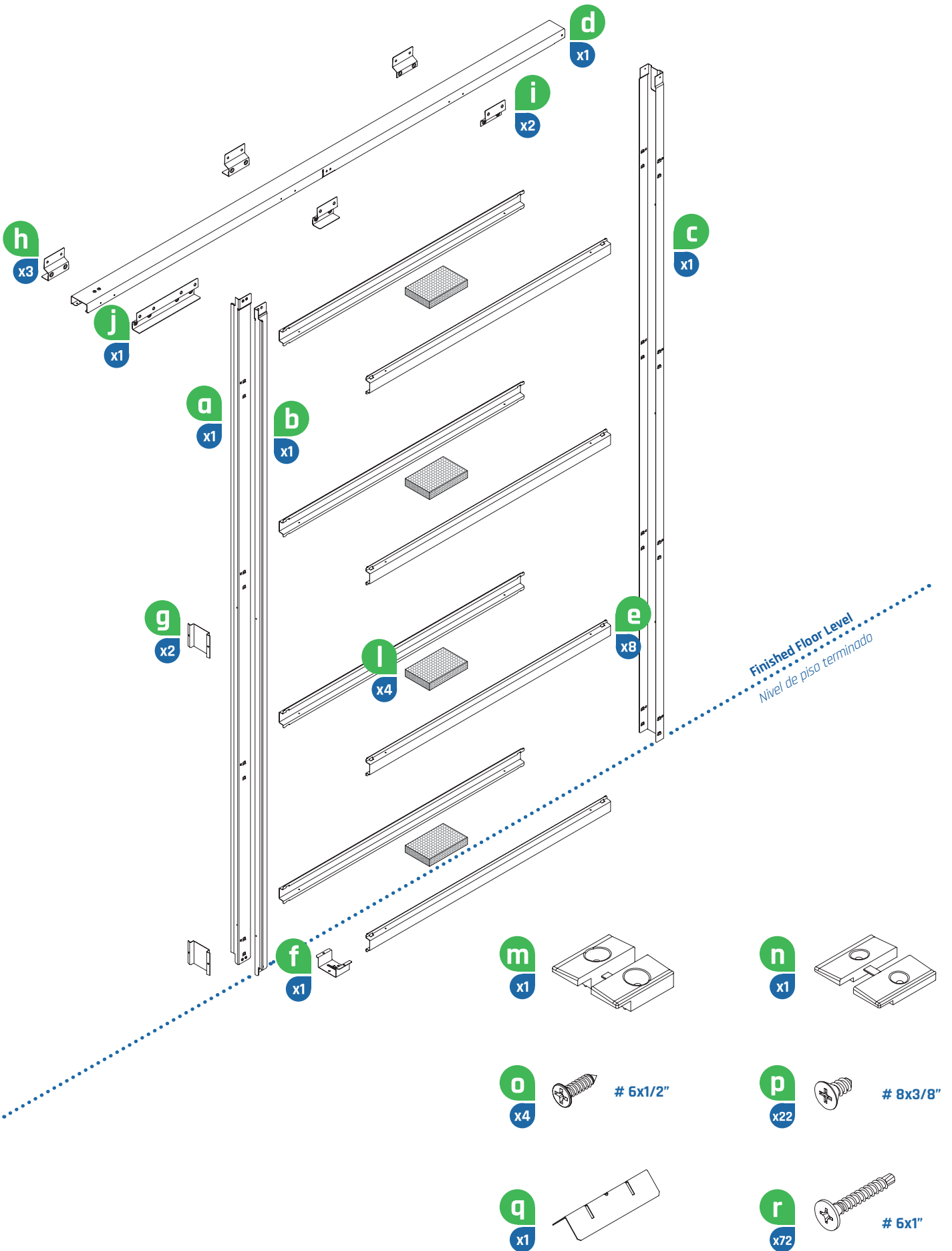

# CONTENTS

## CONTENIDO

**EACH KIT CONTAINS:**  
QUE CONTIENE CADA KIT:

aa  
x2



5/16"

bb  
x2

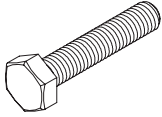

5/16"x1"5/8

cc  
x2



5/16"

dd  
x2



# 6x3/8"

ee  
x8

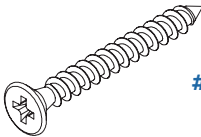

# 6x1"

ff  
x1

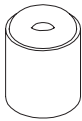

gg  
x1

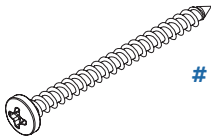

# 8x2"

hh  
x1

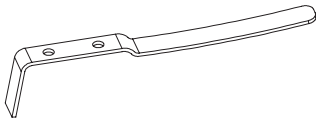

ii  
x2

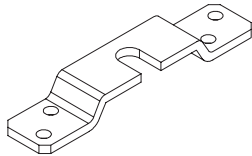

ll  
x2

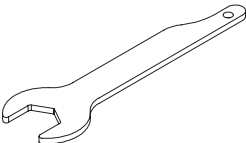

mm  
x2

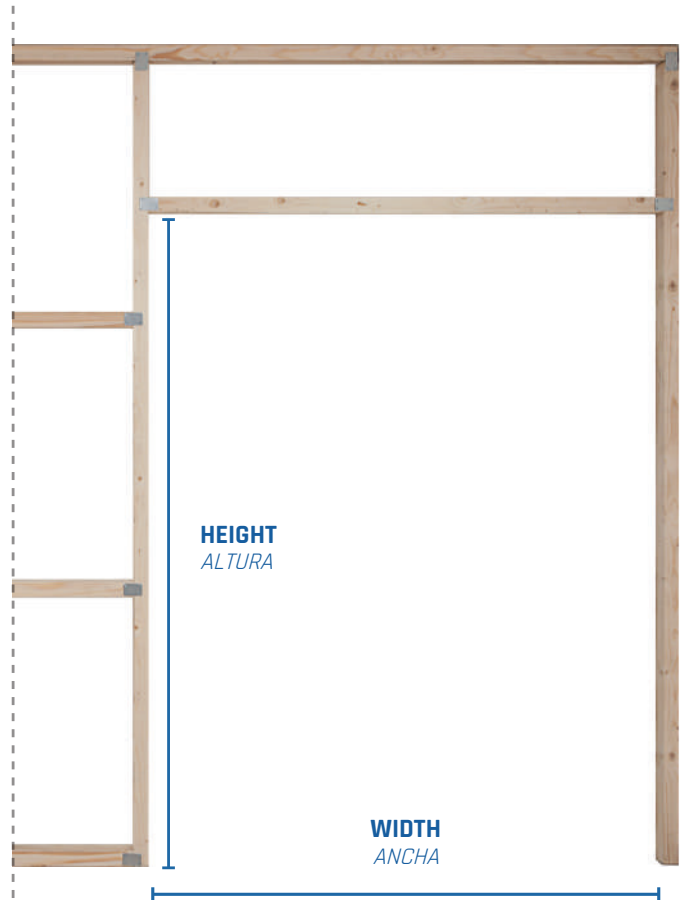
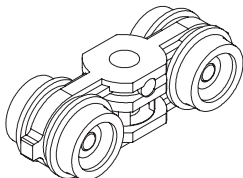

The Rocket Pocket kit will adapt to almost any stud dimension **HOWEVER**, the stud immediately above the frame must be 2x4. You can add layers of plasterboard to this to then obtain the wall thickness you require. Bare in mind the jamb dimensions will change accordingly.

*El kit Rocket Pocket se adaptará a casi cualquier dimensión de montantes, SIN EMBARGO, el montante inmediatamente superior a la estructura debe ser de 2x4. Se pueden añadir placas de yeso a esto para luego obtener el espesor de la pared que usted requiere. Tenga en cuenta que las dimensiones de las jambas cambiarán de consecuencia.*

DOOR PANEL PANEL PUERTA		OVERALL DIMENSIONS MEDIDA TOTAL			
		SINGLE DOOR PUERTA ÚNICA		DOUBLE DOOR PUERTA DOBLE	
DW	DH	W	H	W	H
28"	80"	56" 1/4	82" 7/8	112" 5/8	82" 7/8
30"	80"	60" 3/8	82" 7/8	120" 3/4	82" 7/8
32"	80"	64" 3/8	82" 7/8	128" 3/4	82" 7/8
34"	80"	68" 3/8	82" 7/8	136" 3/4	82" 7/8
36"	80"	72" 1/4	82" 7/8	144" 1/2	82" 7/8

**Door Thickness (Espesor de la puerta): 1" 3/8 - 1" 3/4**

# CHOOSING THE DOOR GUIDE

## ELECCIÓN DE LA GUÍA DE LA PUERTA

FOR WOODEN DOORS ONLY  
SÓLO PARA PUERTAS DE MADERA

DOOR THICKNESS  
ESPESOR DE LA PUERTA

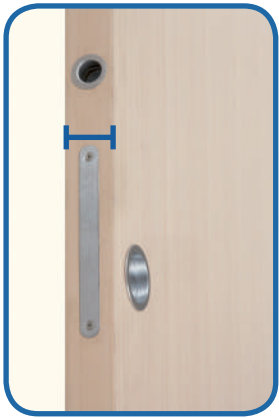

= 1" 3/8

= 1" 3/4

m

n

m1

m2

n1

n2

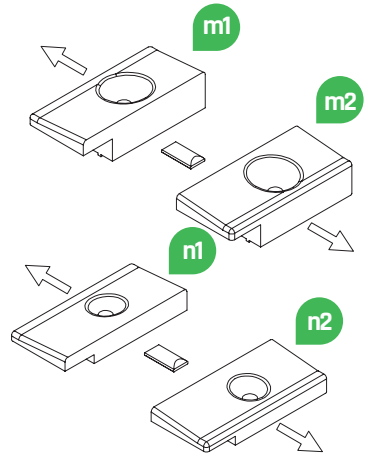
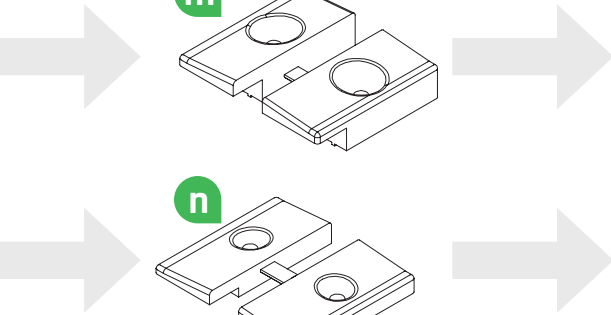

### FOR EXAMPLE 1" 3/8 THICK DOOR

POR EJEMPLO, UNA PUERTA DE 1" 3/8 DE ESPESOR

b

a



m2

o

m1

o

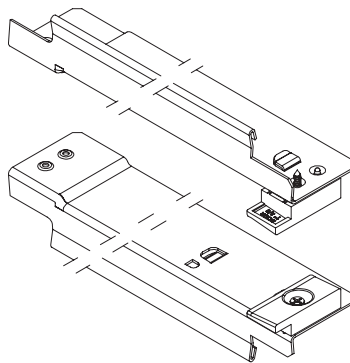

OK

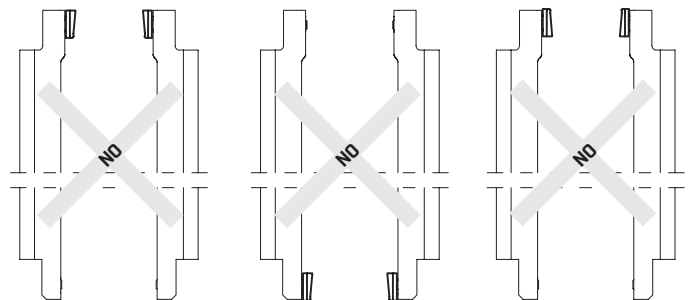
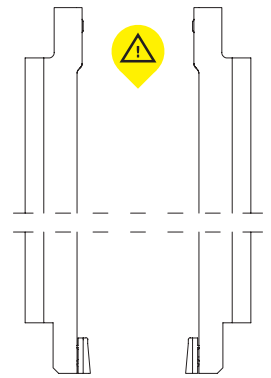

# ATTACHING THE BRACKETS

FIJACIÓN DE LOS SOPORTES

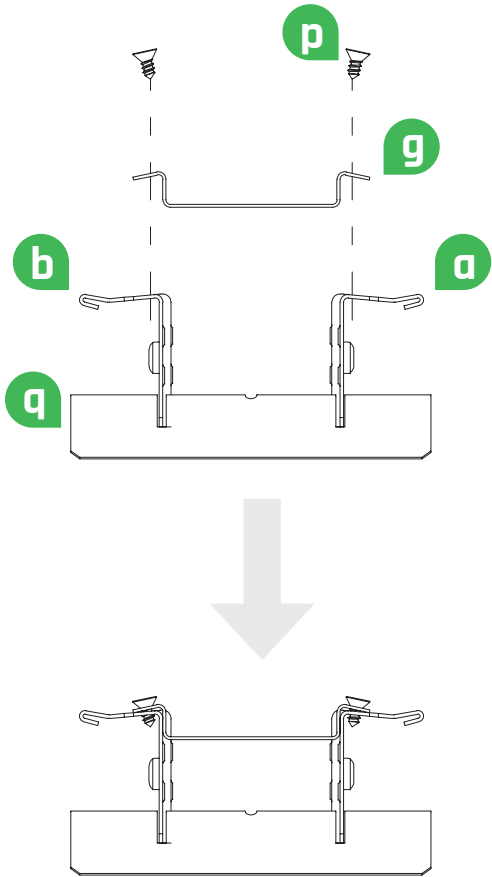
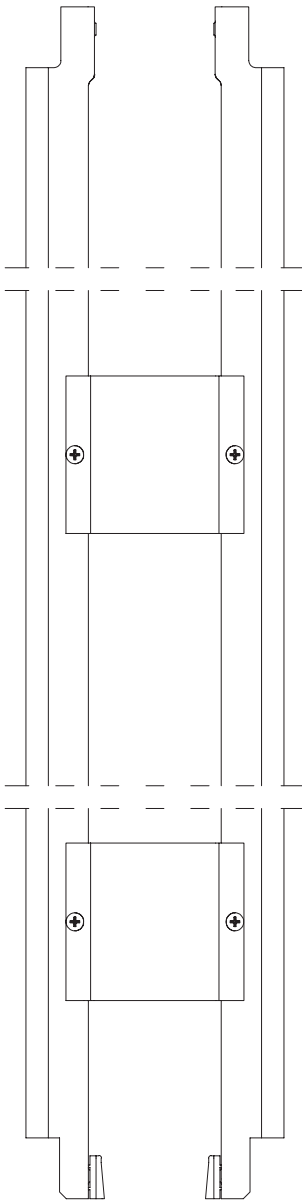
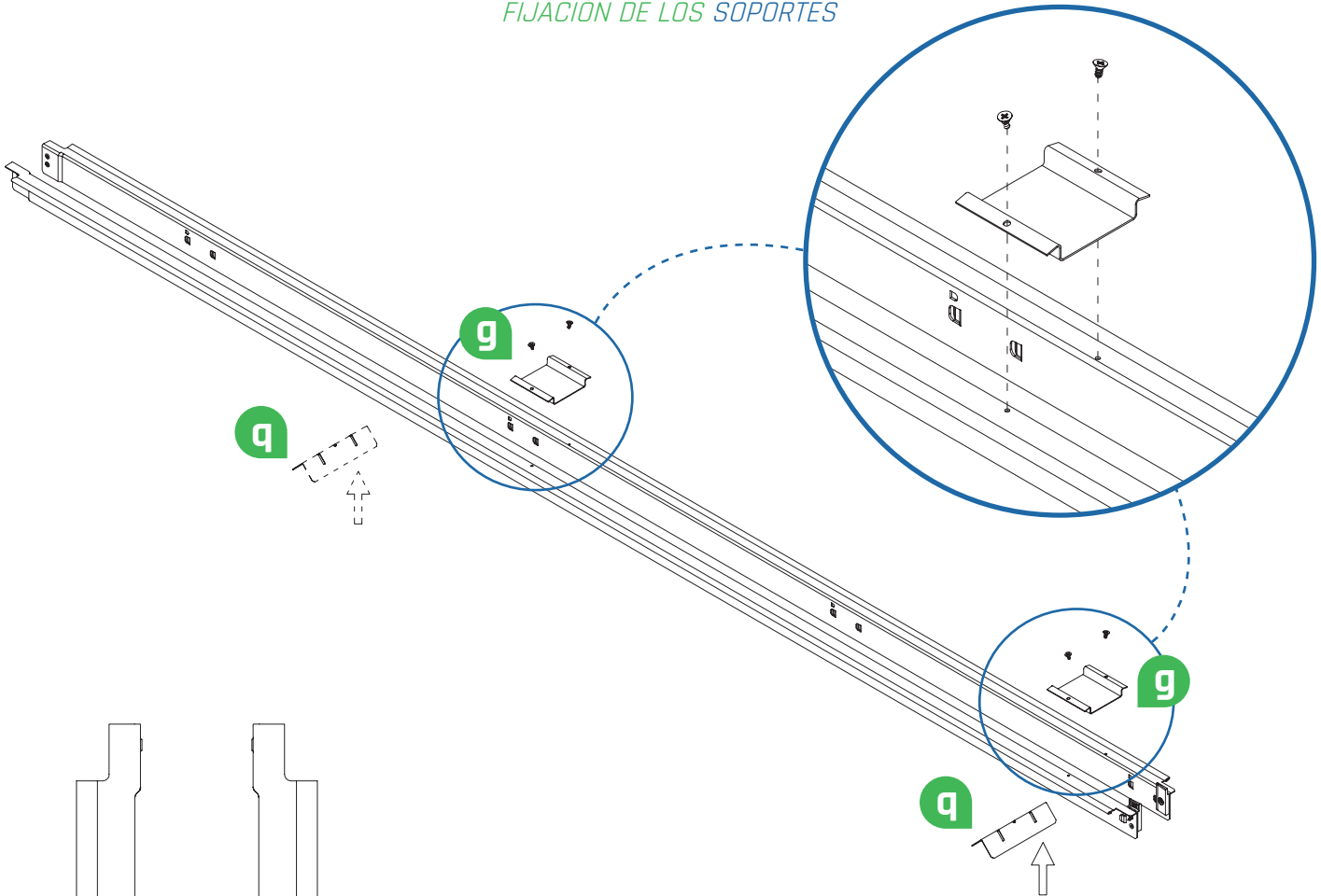

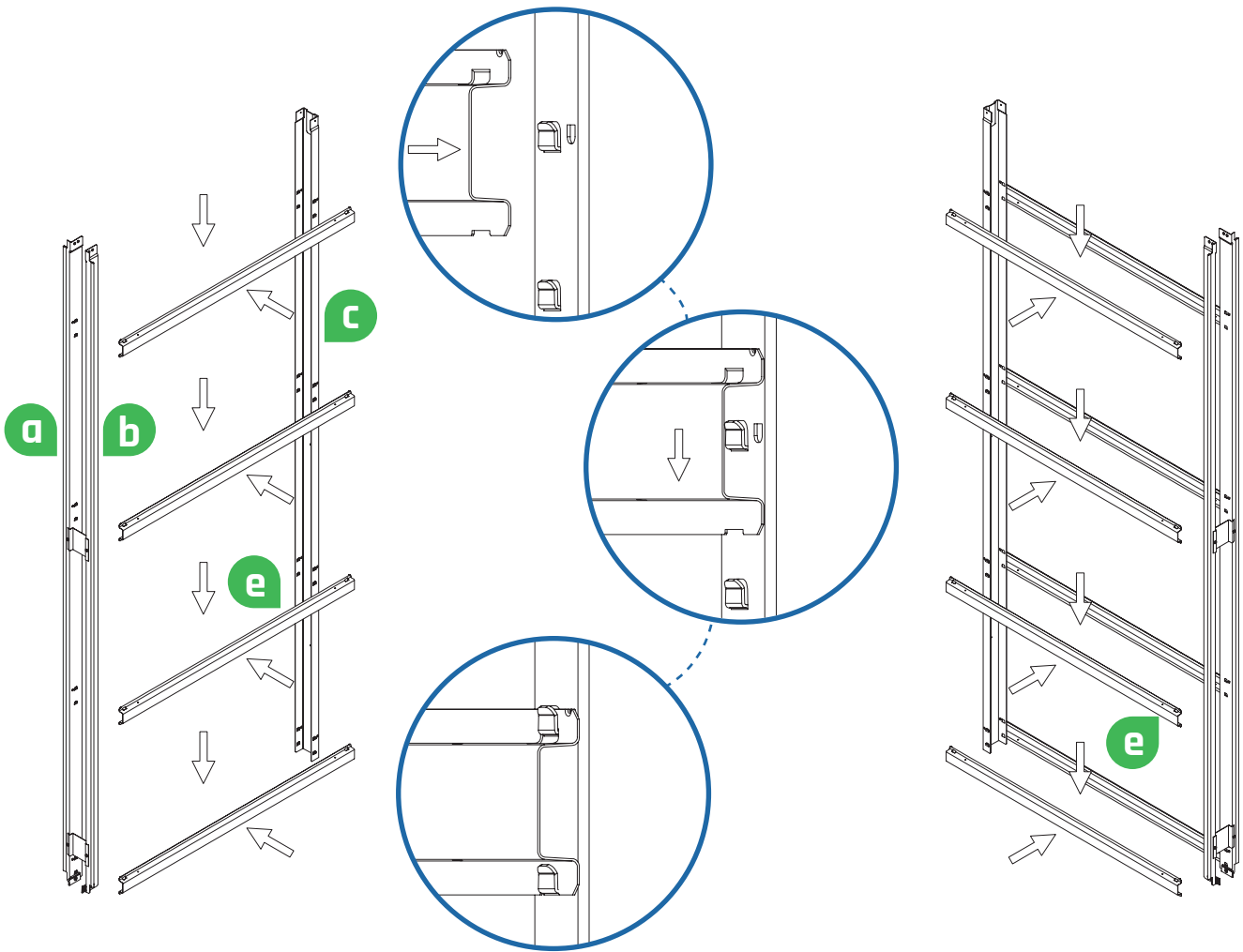

**FRAME ASSEMBLING**  
*MONTAJE DEL MARCO*

**Insert polystyrene spacers**  
*Insertar espaciadores de poliestireno*

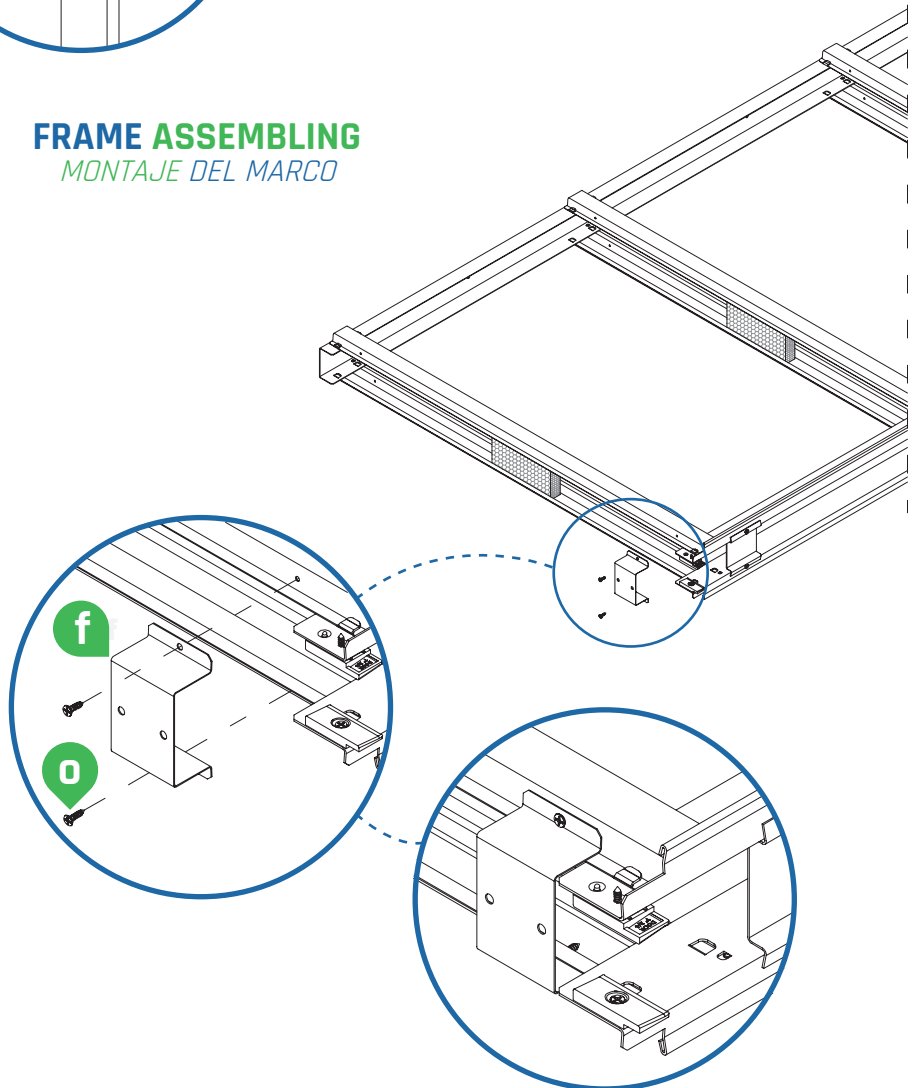
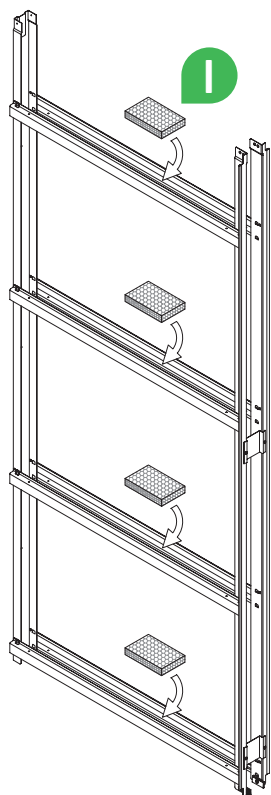

# ATTACHING THE BRACKETS

## FIJACIÓN DE LOS SOPORTES

Assemble top brackets **h** and **j** on one side only for the moment. Note the brackets are different so position correctly

Ensamblar los soportes superiores **h** y **j** en un solo lado por el momento. Observe que los soportes son diferentes. Colocar correctamente en la posición como indicado en el dibujo

SINGLE DOOR  
PUERTA ÚNICA

DOUBLE DOOR  
PUERTA DOBLE

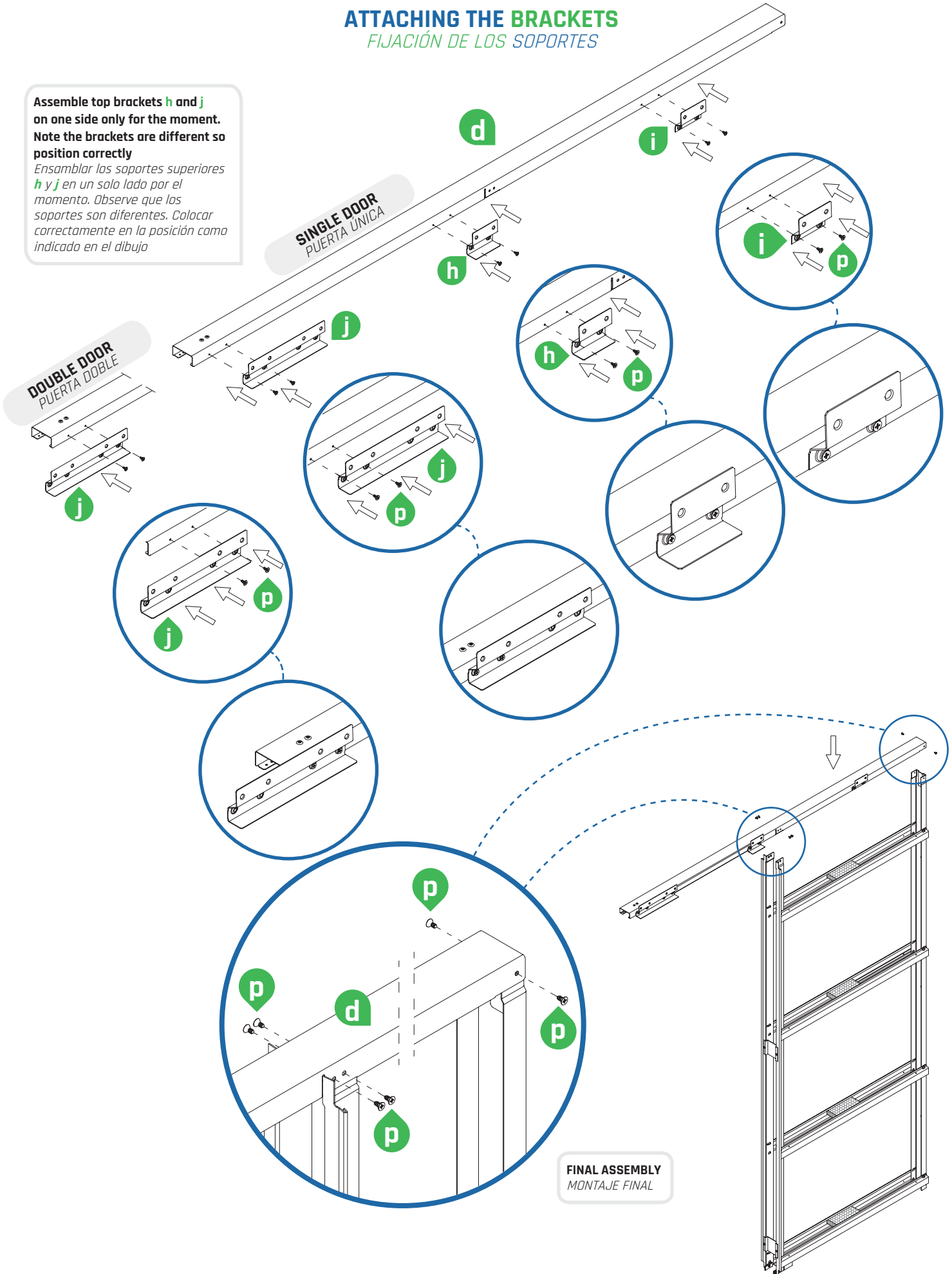

FINAL ASSEMBLY  
MONTAJE FINAL



**SINGLE DOOR** *PUERTA ÚNICA*

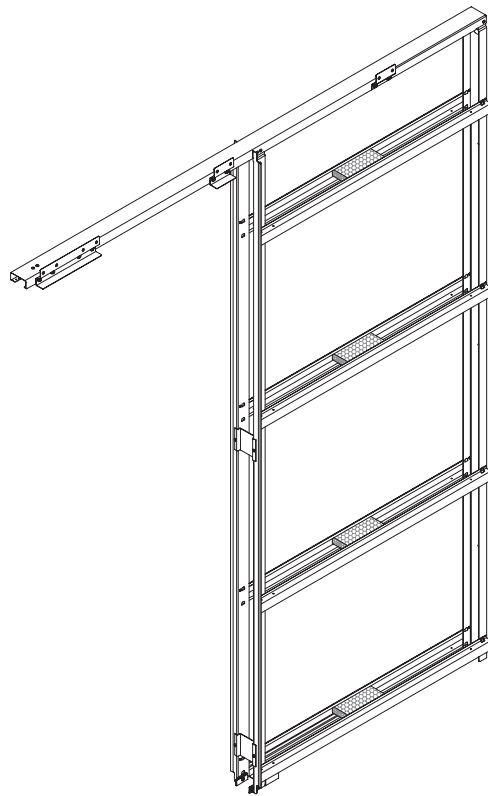

**DOUBLE DOOR** *PUERTA DOBLE*

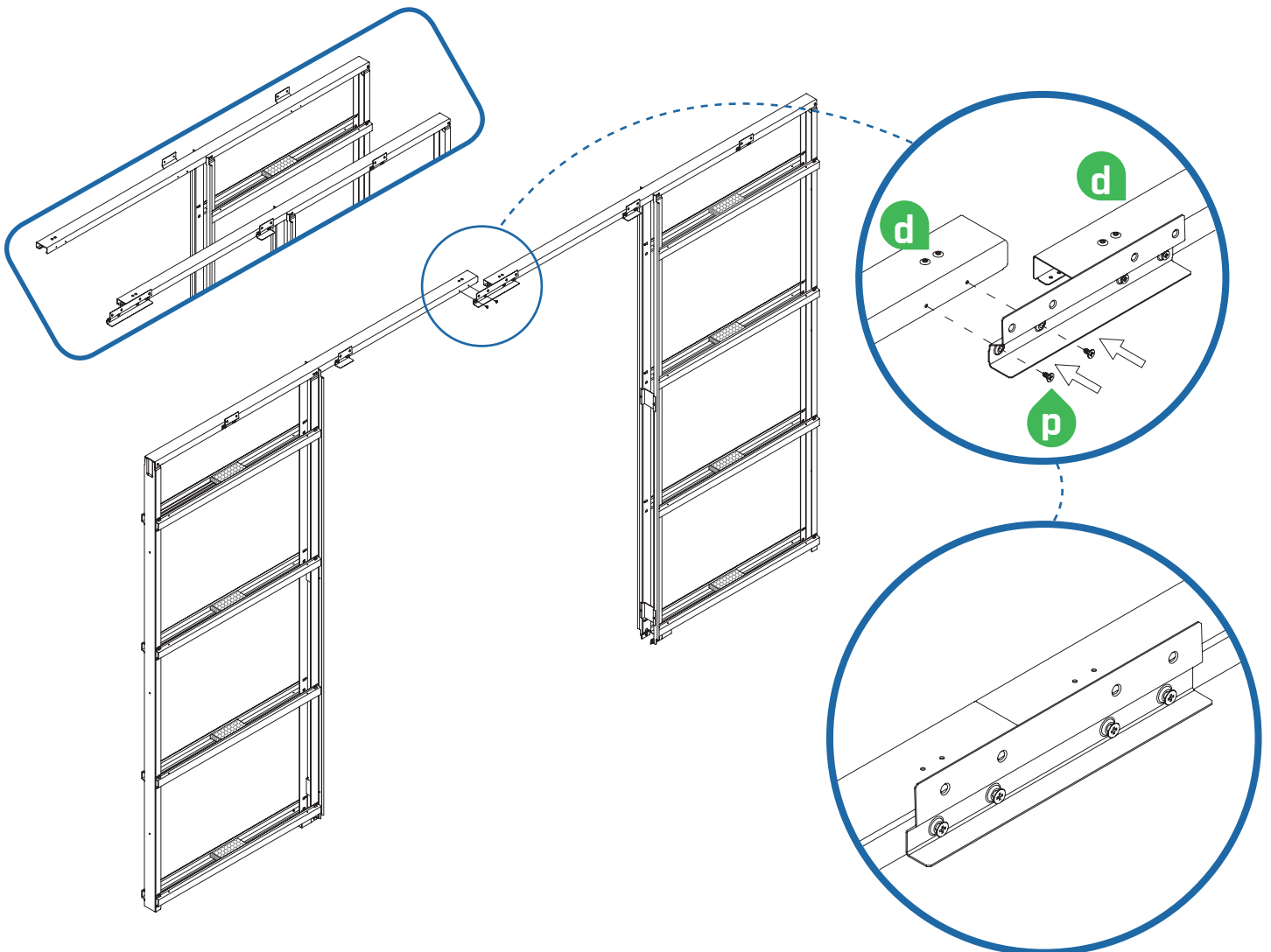

# INSTALLING IN STUDWORK

INSTALACIÓN EN LA ESTRUCTURA LIVIANA

## SINGLE DOOR PUERTA ÚNICA

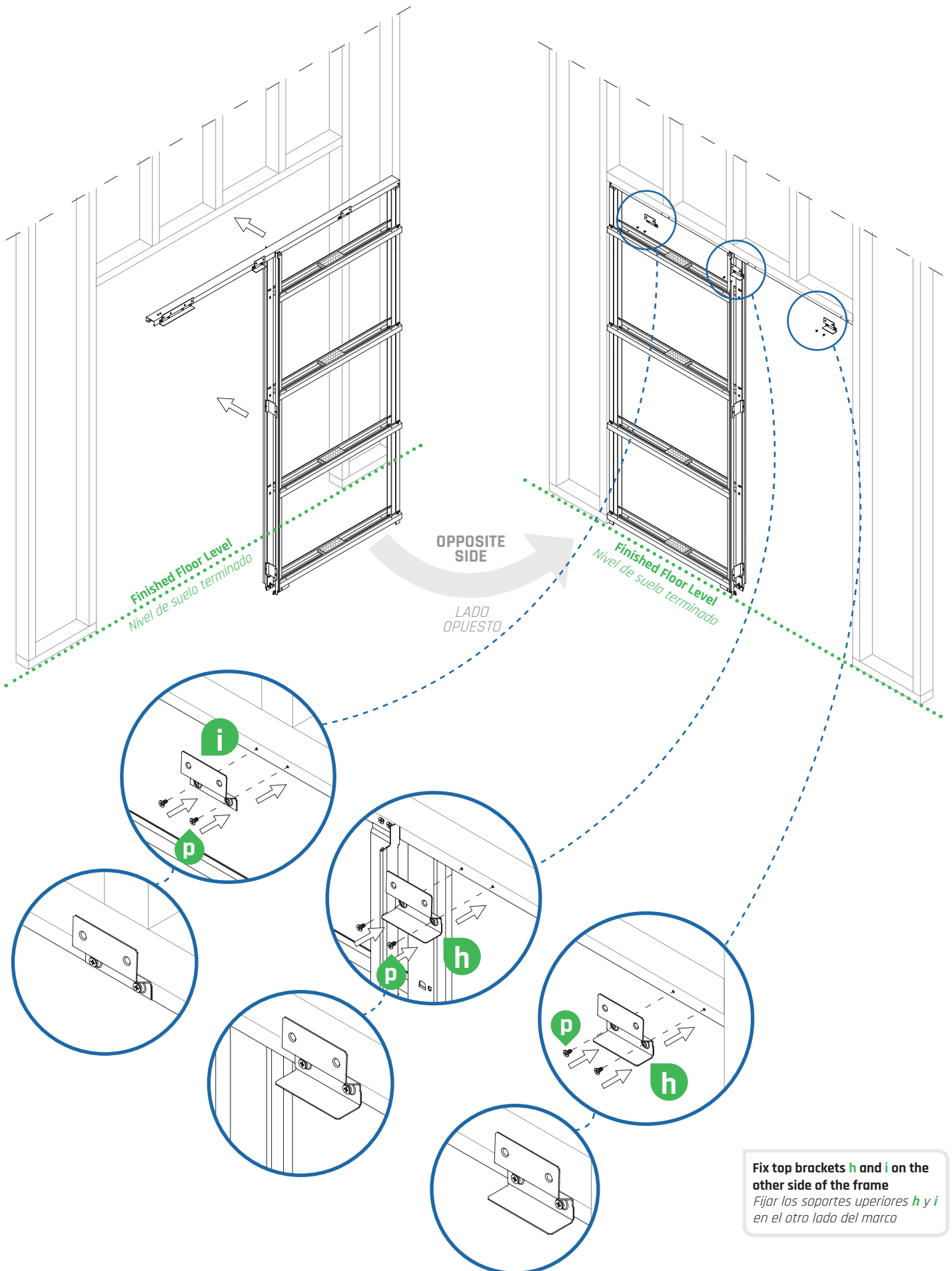

**Fix top brackets **h** and **i** on the other side of the frame**  
*Fijar los soportes superiores **h** y **i** en el otro lado del marco*

# INSTALLING IN STUDWORK

INSTALACIÓN EN LA ESTRUCTURA LIVIANA

## DOUBLE DOOR PUERTA DOBLE

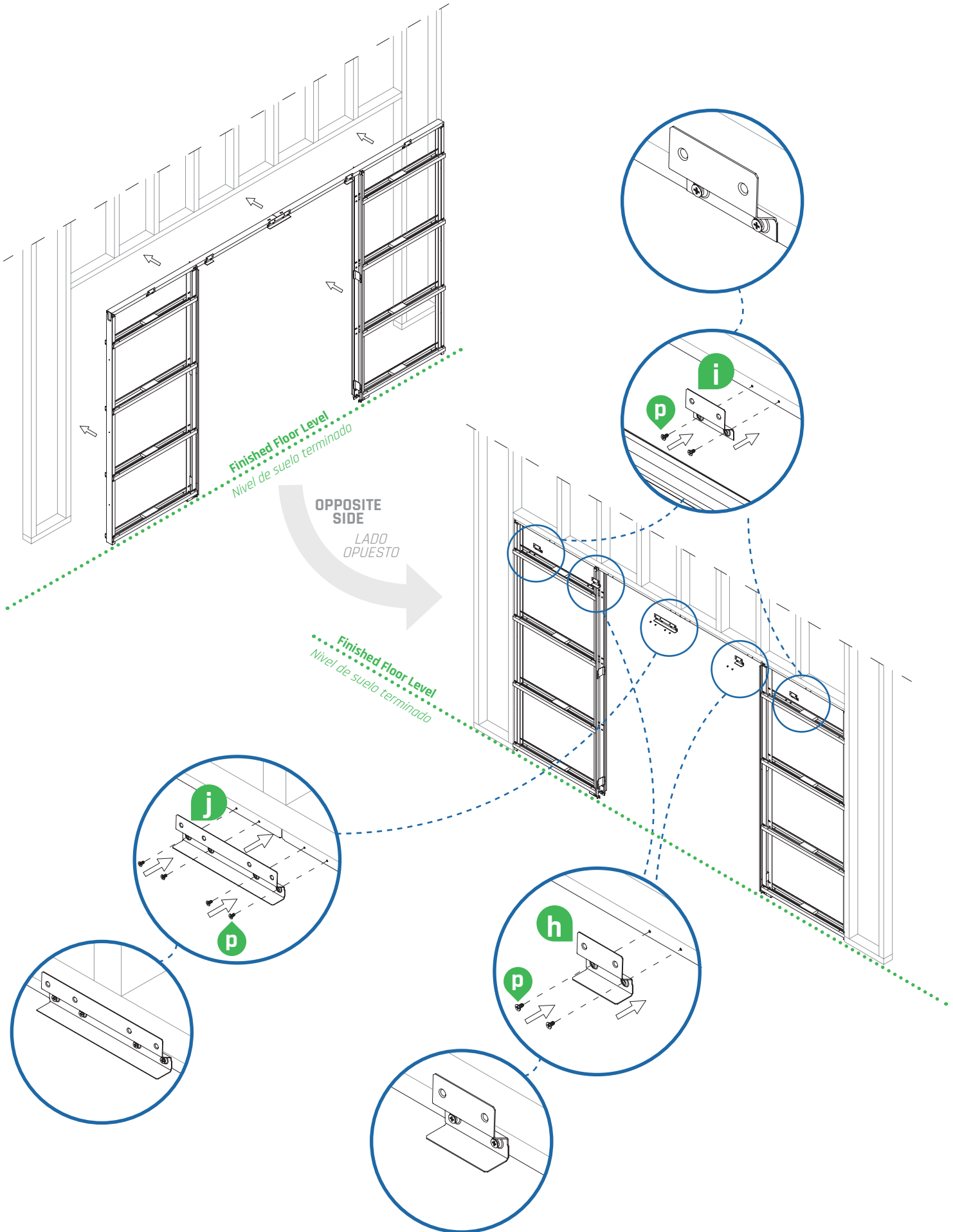

# INSTALLING IN STUDWORK

INSTALACIÓN EN LA ESTRUCTURA LIVIANA

## SINGLE DOOR PUERTA ÚNICA

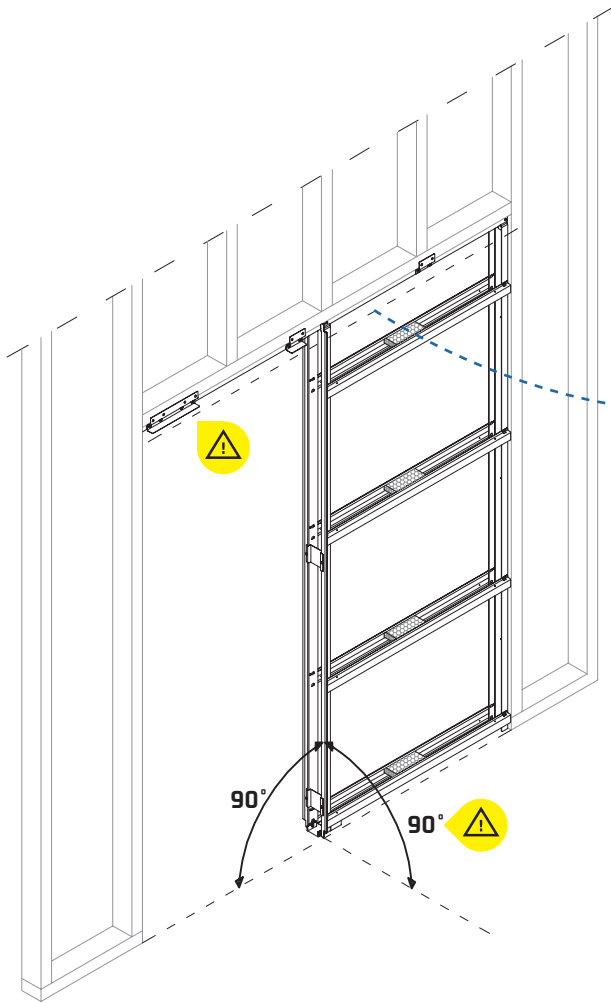

**Ensure frame is plumb and square**  
*Asegurarse de que el marco es a plomo y a escuadra*

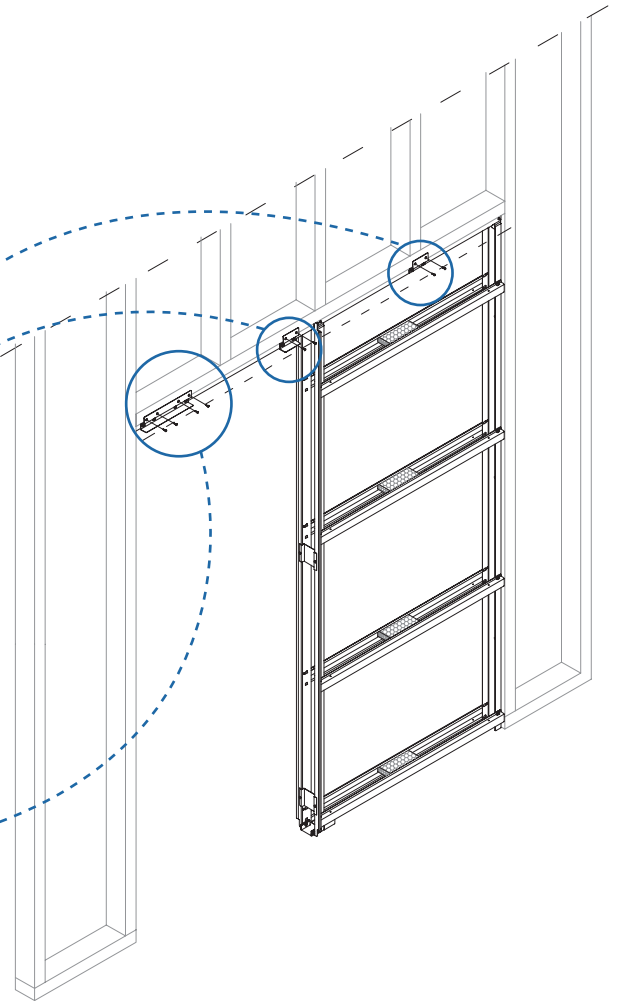
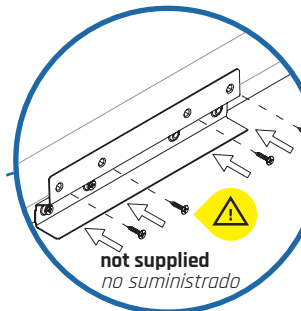
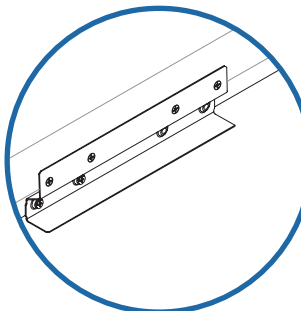
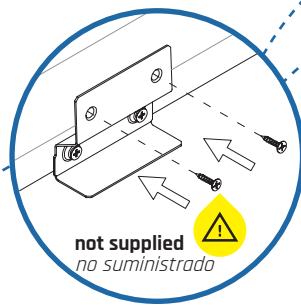
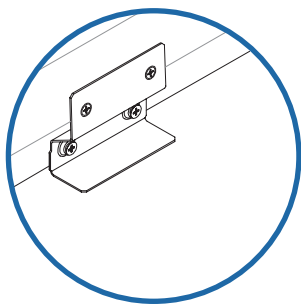

# INSTALLING IN STUDWORK

INSTALACIÓN EN LA ESTRUCTURA LIVIANA

## DOUBLE DOOR PUERTA DOBLE

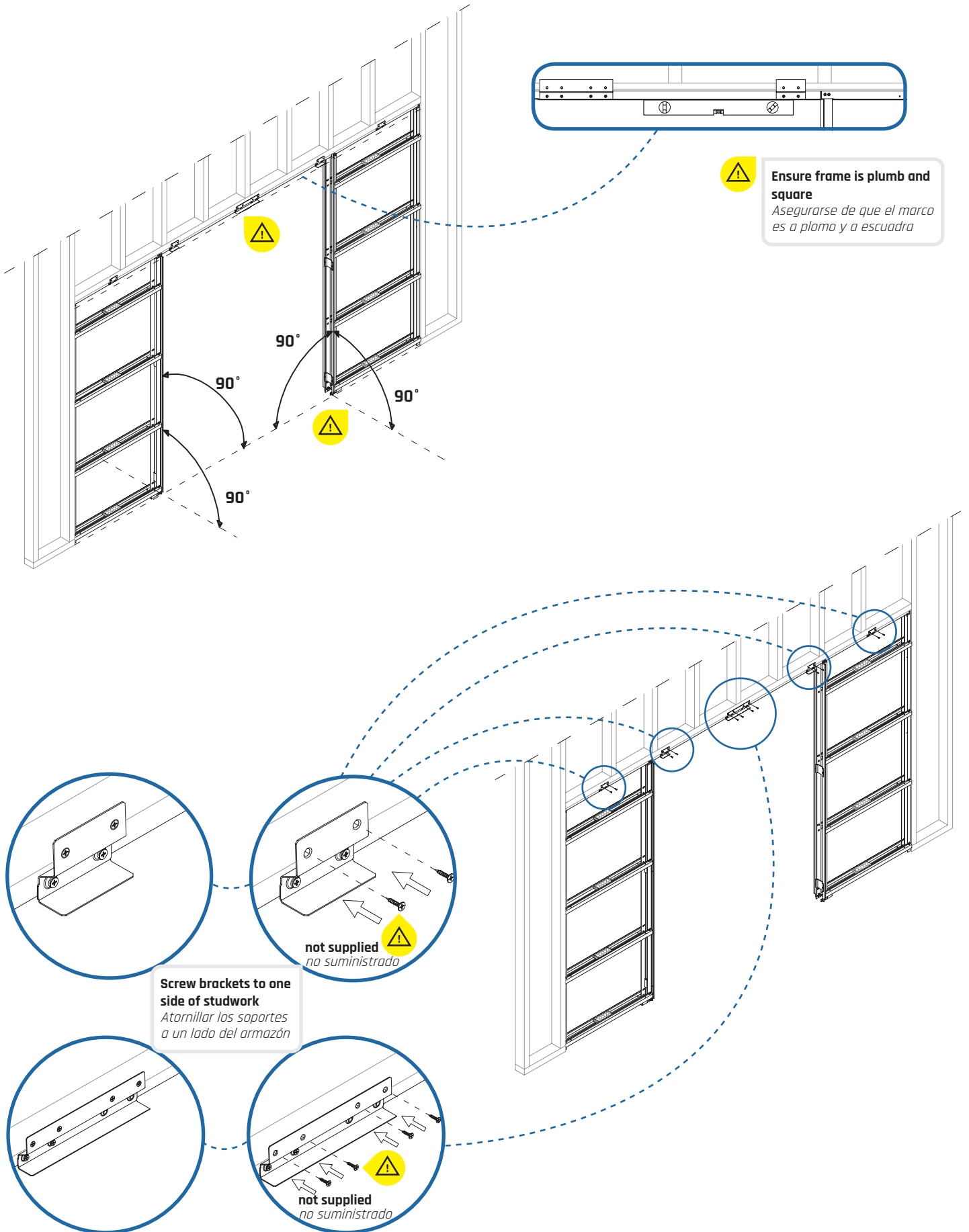

# INSTALLING IN STUDWORK

## INSTALACIÓN EN LA ESTRUCTURA LIVIANA

### SINGLE DOOR PUERTA ÚNICA

### DOUBLE DOOR PUERTA DOBLE

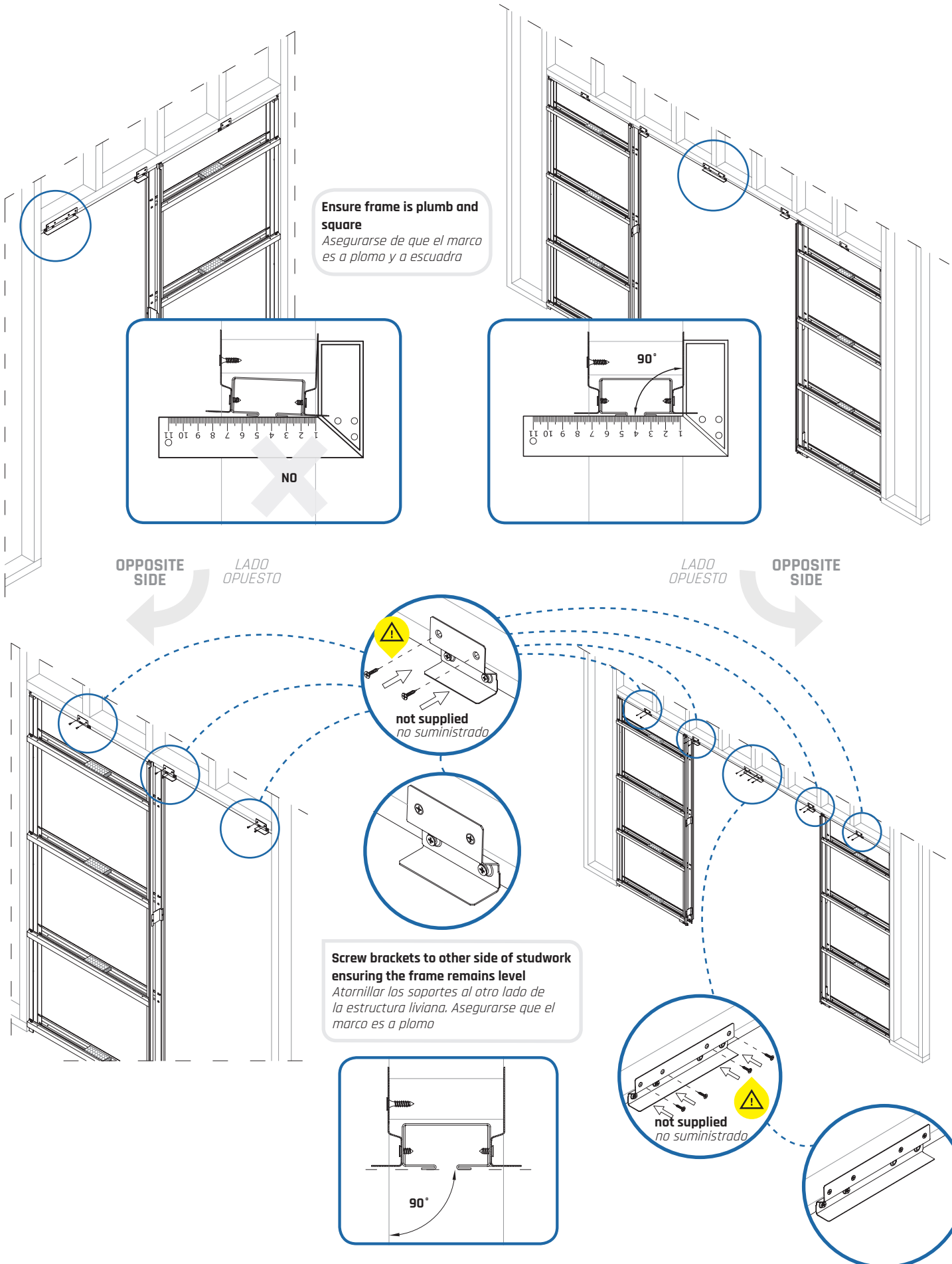

# INSTALLING IN STUDWORK

INSTALACIÓN EN LA ESTRUCTURA LIVIANA

## SINGLE DOOR PUERTA ÚNICA

## DOUBLE DOOR PUERTA DOBLE

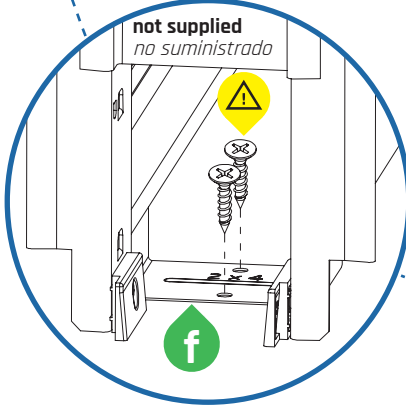
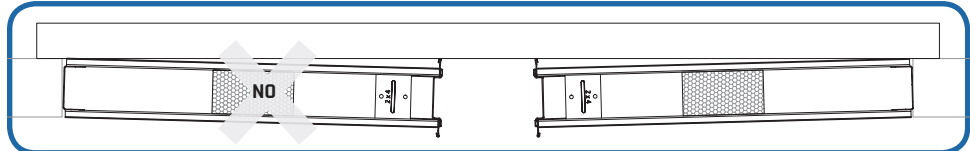
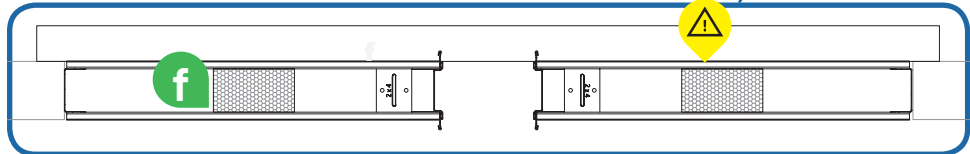
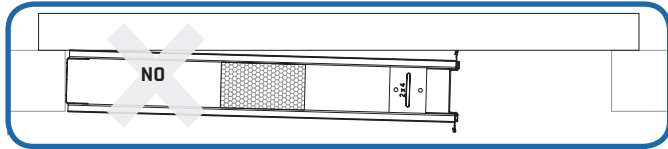
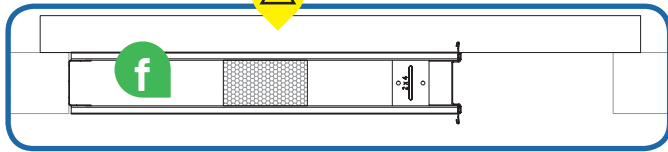
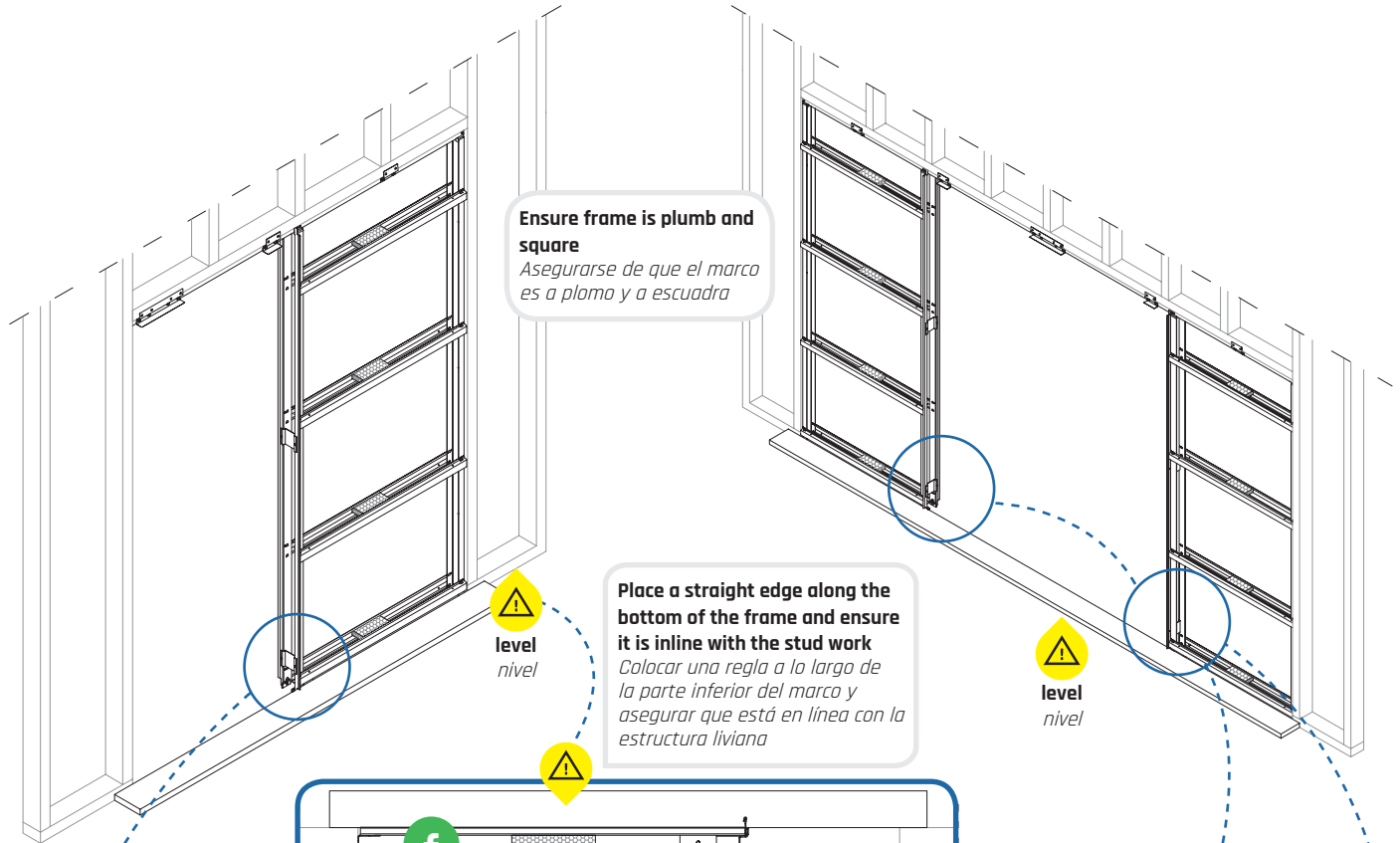

not supplied  
*no suministrado*

**Screw the U section f to the floor**  
*Atornillar la sección f al suelo*

## SCREWING THE REAR VERTICAL TO THE STUDWORK

ATORNILLAR LA PARTE TRASERA DEL ARMazón A LA ESTRUCTURA LIVIANA

**SINGLE DOOR** PUERTA ÚNICA

**DOUBLE DOOR** PUERTA DOBLE

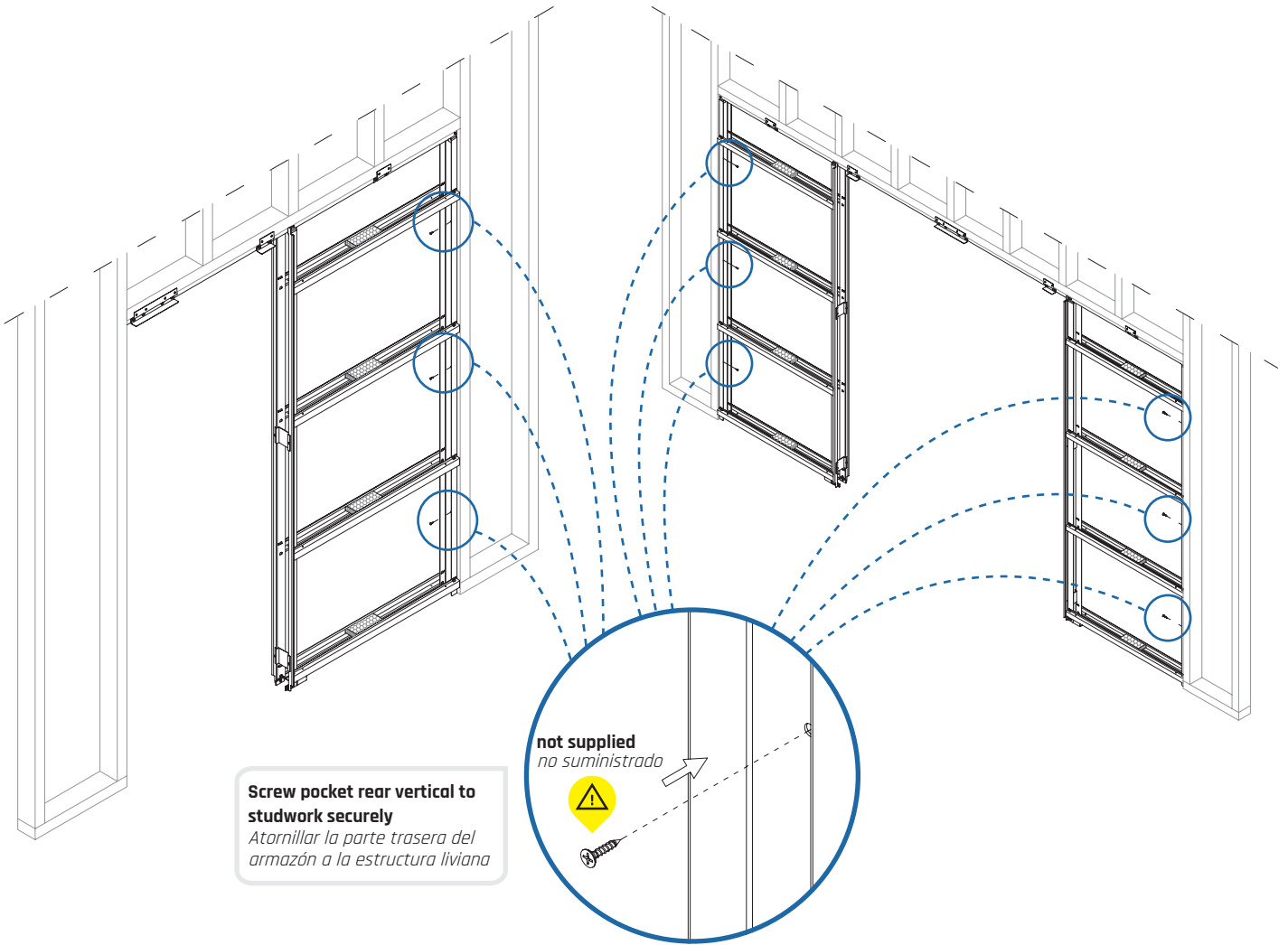

x2

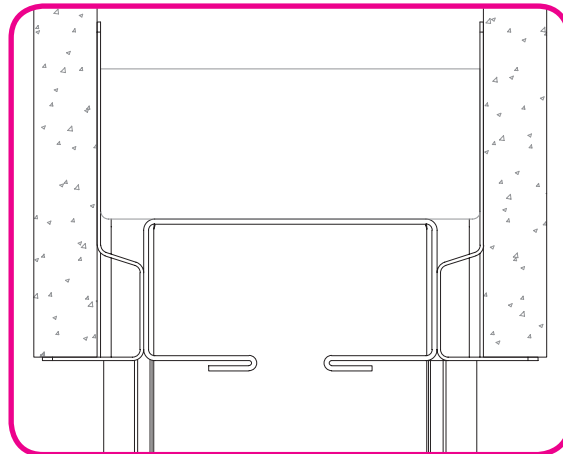

**CAREFULLY CLEAN THE TRACK TWICE**  
*LIMPIAR CUIDADOSAMENTE EL RIEL DOS VECES*



# FIXING THE PLASTERBOARD

FIJACIÓN DE LA PLACA DE YESO

**SINGLE DOOR** PUERTA ÚNICA

**DOUBLE DOOR** PUERTA DOBLE

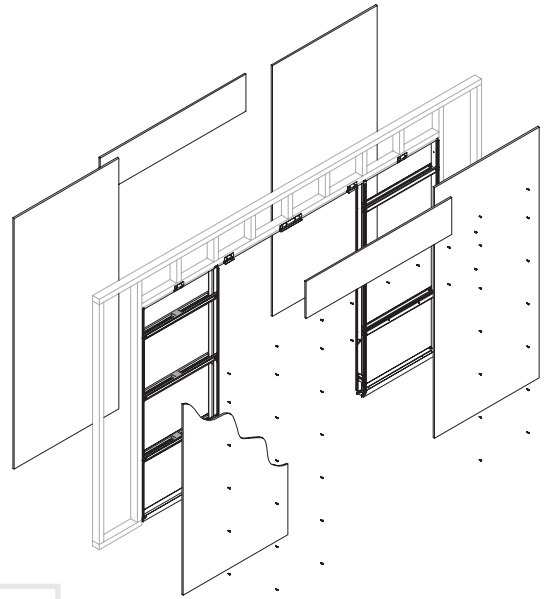
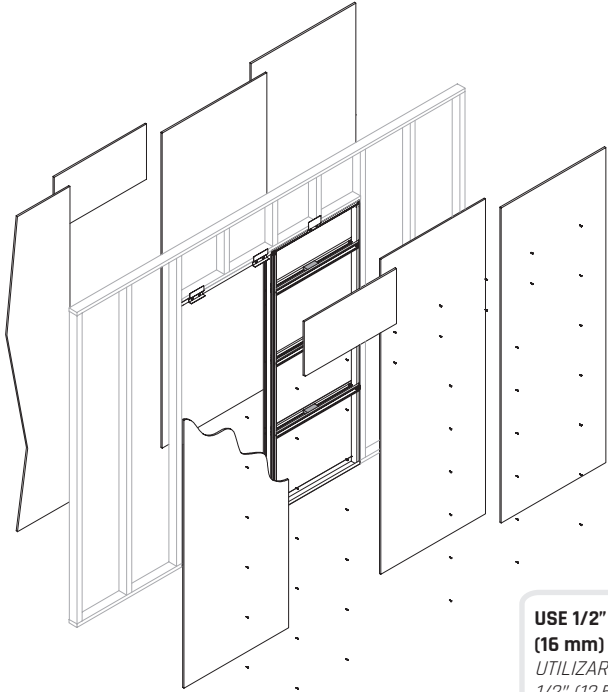

USE 1/2" (12.5 mm) OR 5/8"  
(16 mm) PLASTERBOARD  
UTILIZAR PLACAS DE YESO DE  
1/2" (12.5 mm) o 5/8" (16 mm)

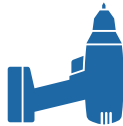
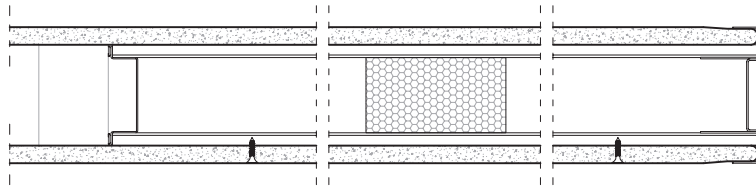

Use supplied 1" (25 mm)  
screws  
Use tornillos de 1" (25 mm)  
suministrados

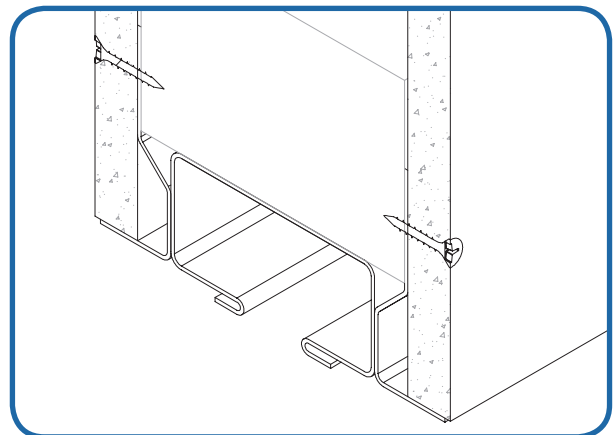
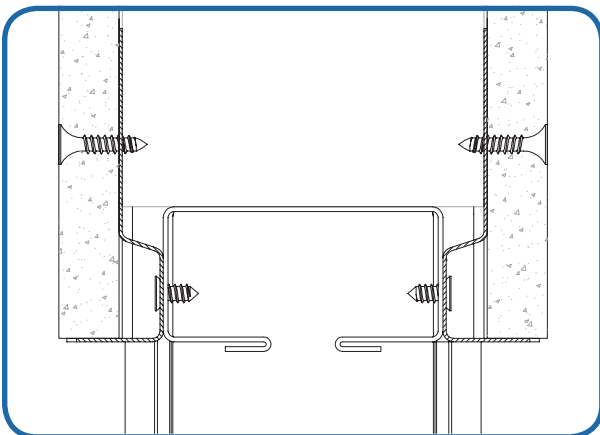

# REMOVING BRACKETS AND SPACERS

QUITAR LOS SOPORTES Y DISTANCIADORES

SINGLE DOOR PUERTA ÚNICA

DOUBLE DOOR PUERTA DOBLE

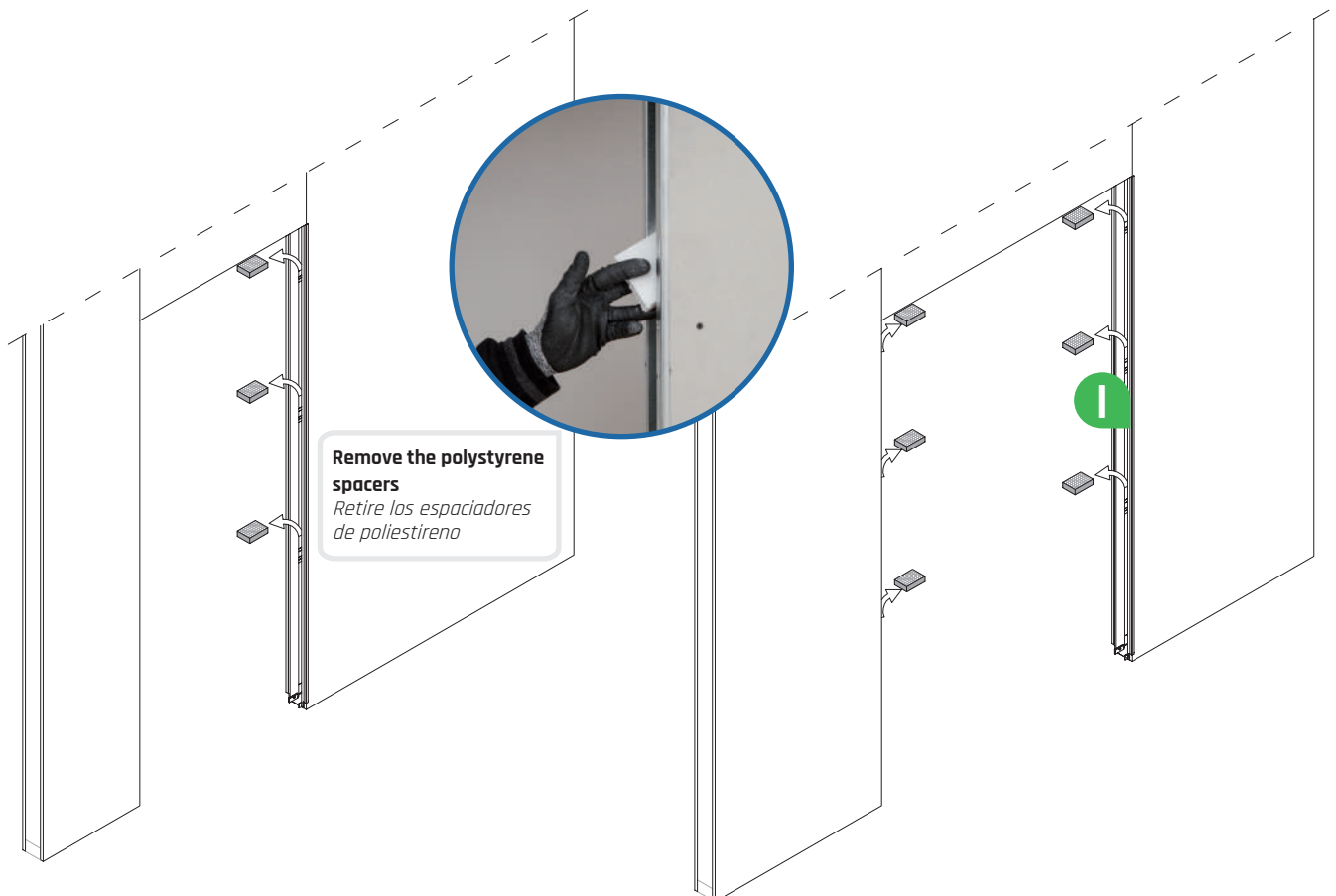
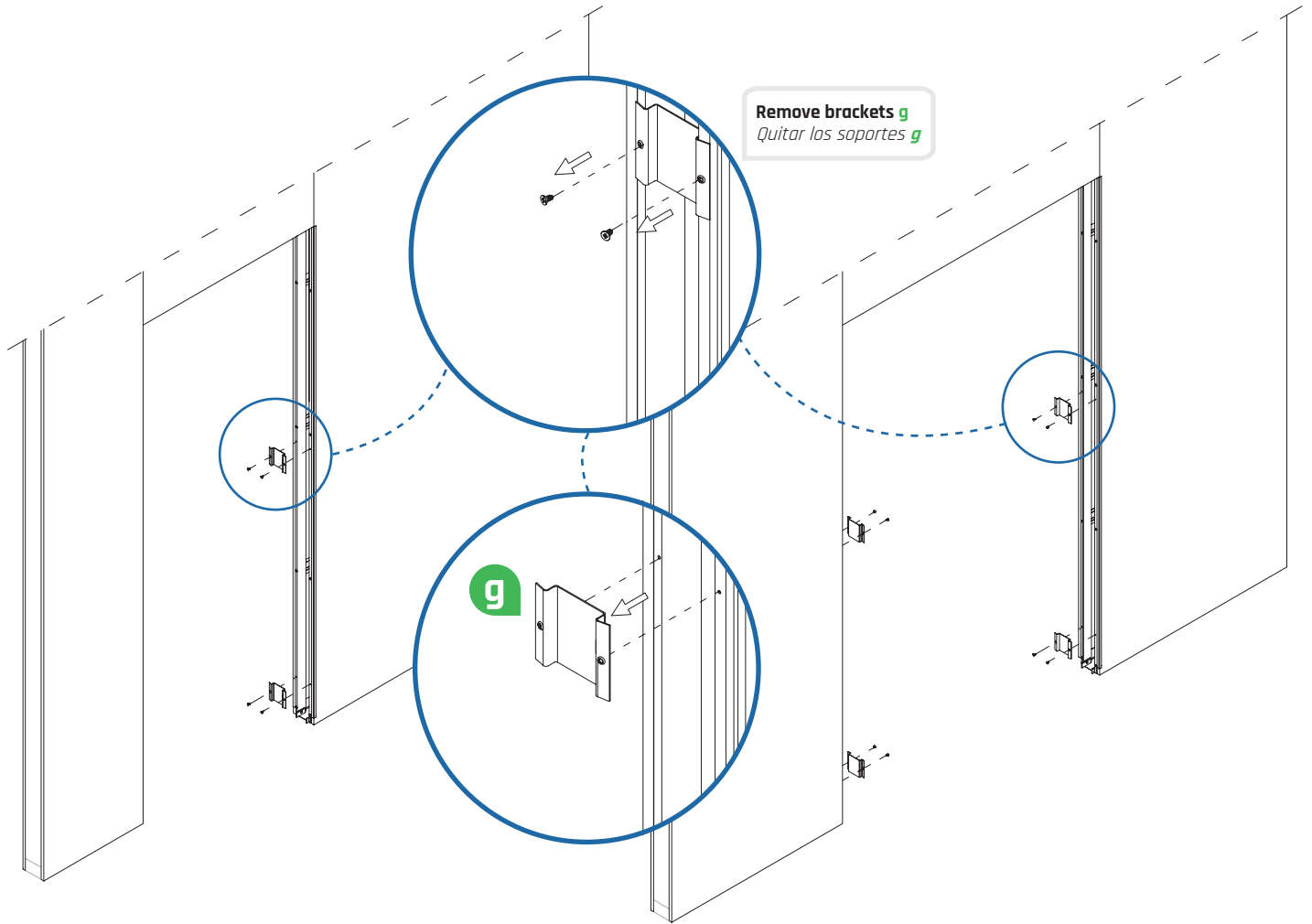

## RUNNERS ASSEMBLING

MONTAJE DE LOS CARROS DE DESLIZAMIENTO

**X2**

**SINGLE DOOR** PUERTA ÚNICA

**X4**

**DOUBLE DOOR** PUERTA DOBLE

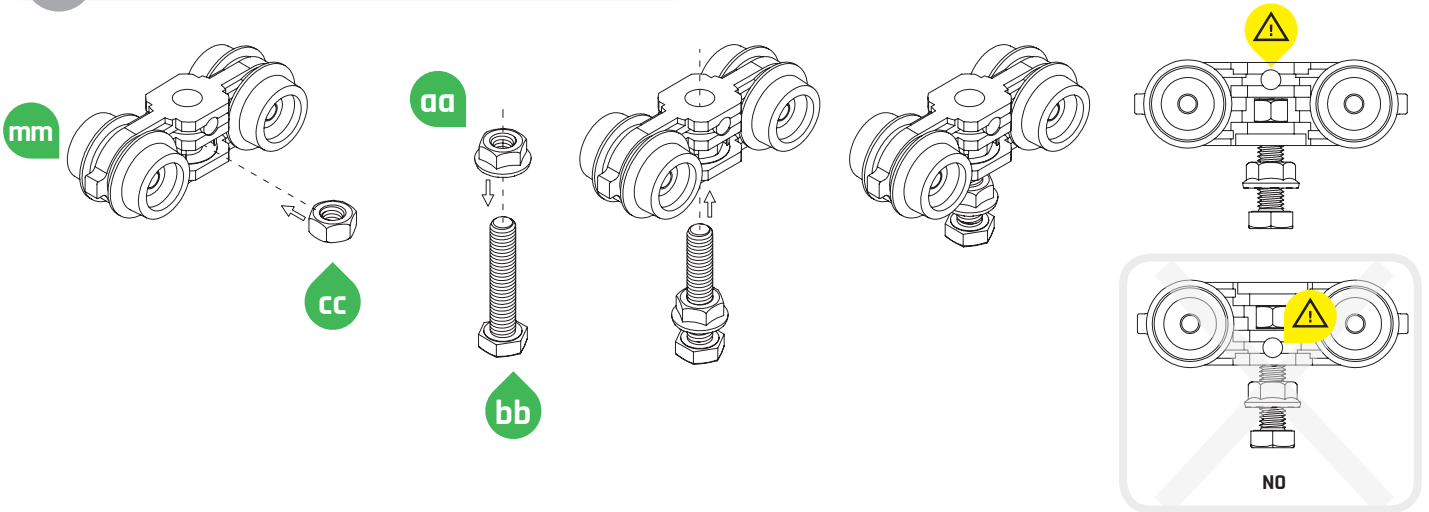

## INSERT RUNNERS INTO TRACK

INSERTAR LOS CARROS DE DESLIZAMIENTO EN EL RIEL

**SINGLE DOOR** PUERTA ÚNICA

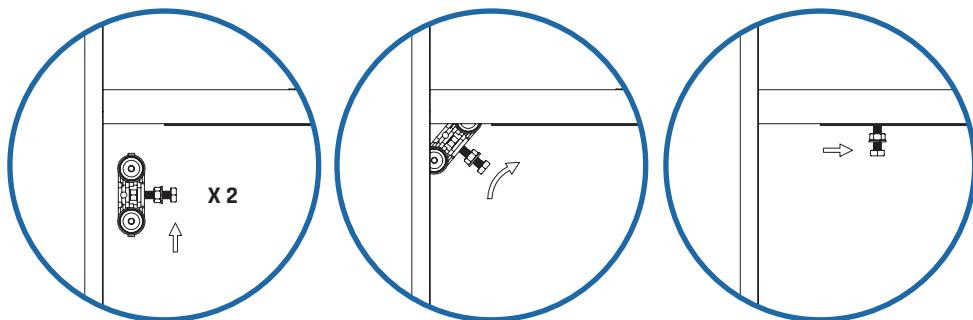

**DOUBLE DOOR** PUERTA DOBLE

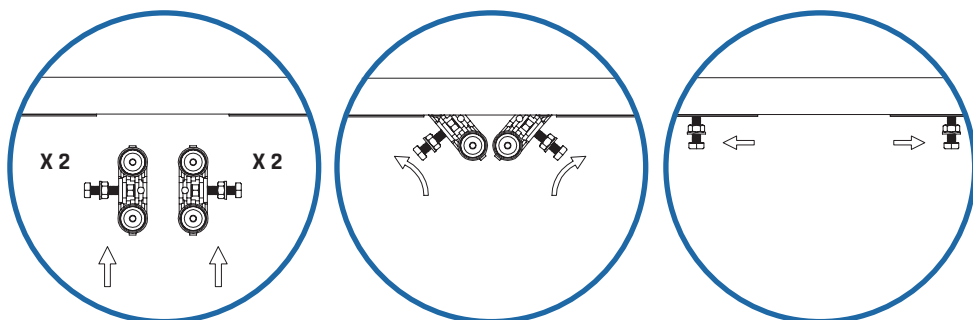

# INSTALLING DOOR BRACKETS

INSTALACIÓN DE LOS SOPORTES DE LA PUERTA

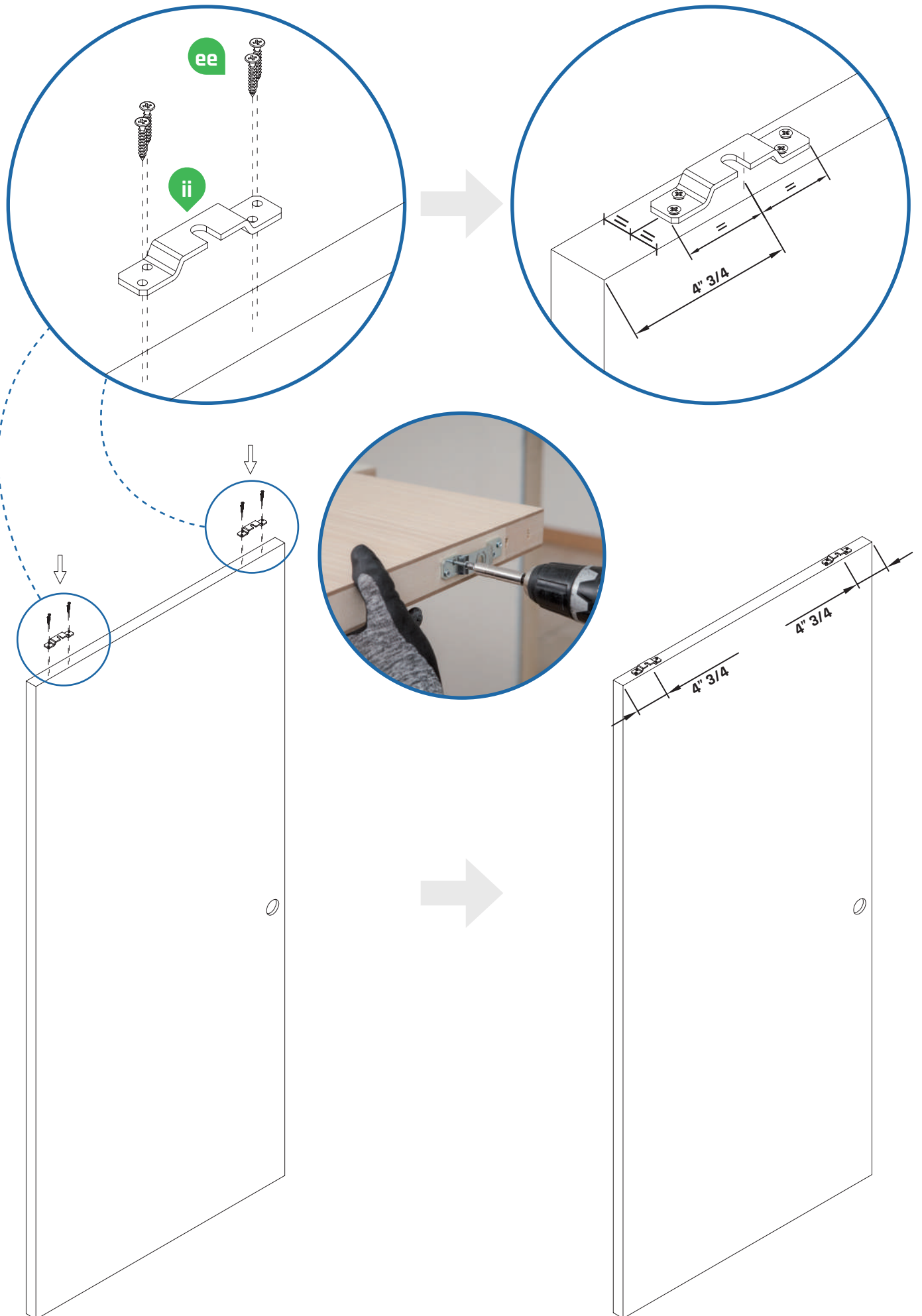

## INSTALLING REAR DOOR BUMPER

INSTALACIÓN DEL PARACHOQUES DE LA PUERTA TRASERA

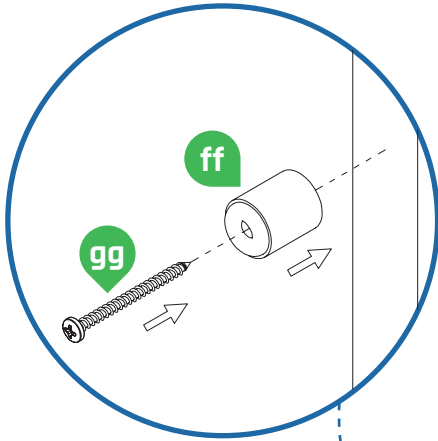

**Screw in front doorstop using supplied screws and pre drilled holes**

*Atornillar el tope de la puerta delantera utilizando los tornillos suministrados*

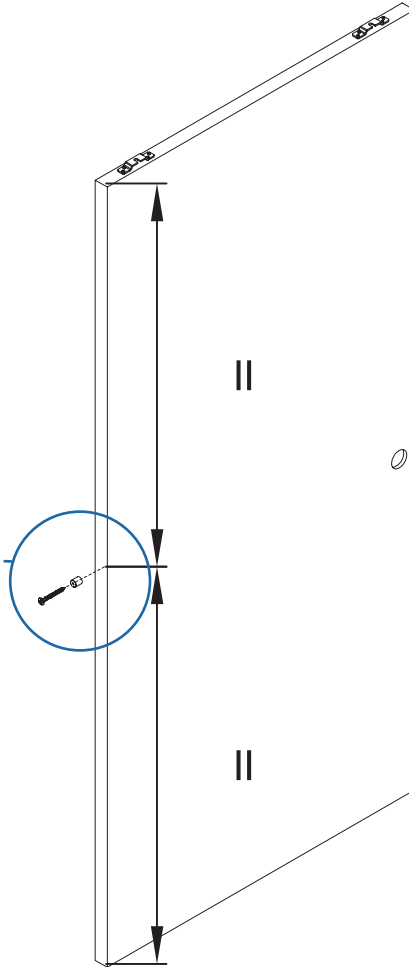

**If you wish to adjust the door to protrude from the pocket when fully open, you need to add a distance piece between the rear of the door and the rubber bumper. We recommend this when using flush pulls to eliminate the risk of trapped fingers.**

*Si desea ajustar la puerta que sobresalga del sistema totalmente abierto, necesitas añadir una pieza entre la parte trasera de la puerta y el parachoques de goma. Recomendamos esto, cuando se utilizan manillas enrasadas para eliminar el riesgo de dañar los dedos.*

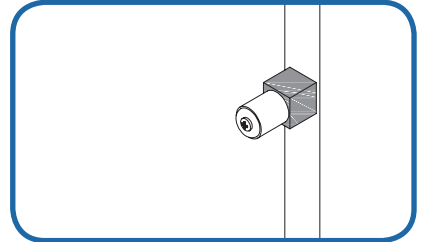
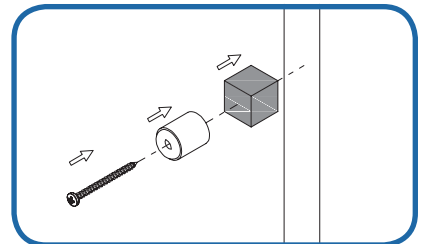

## INSTALLING DOOR PANEL

INSTALACIÓN DEL PANEL DE LA PUERTA

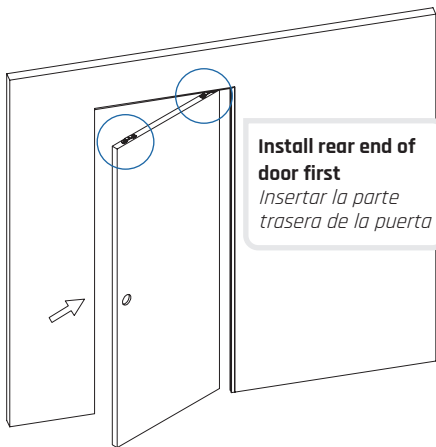

**Install rear end of door first**

*Insertar la parte trasera de la puerta*

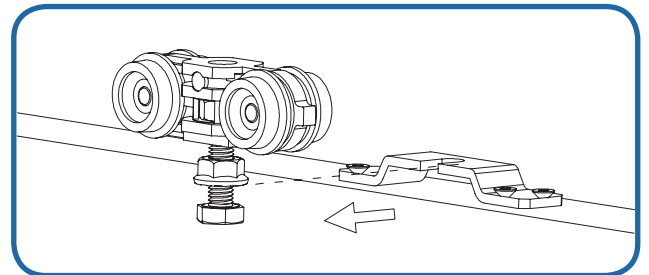
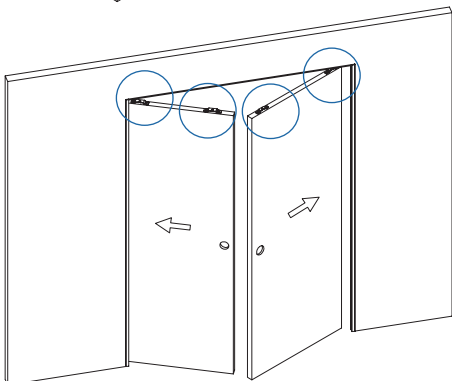

**Adjust door height to be 1/4" (7 mm) above the floor and lock into position with by tightening lock nut**

*Ajuste la altura de la puerta a 1/4" (7 mm) sobre el suelo y bloquear en posición apretando la tuerca de seguridad*

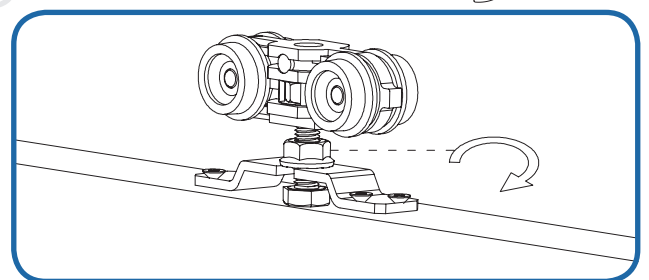

# INSTALLING DOOR BRAKE

## INSTALACIÓN DEL FRENO DE PUERTA

### SINGLE DOOR PUERTA ÚNICA

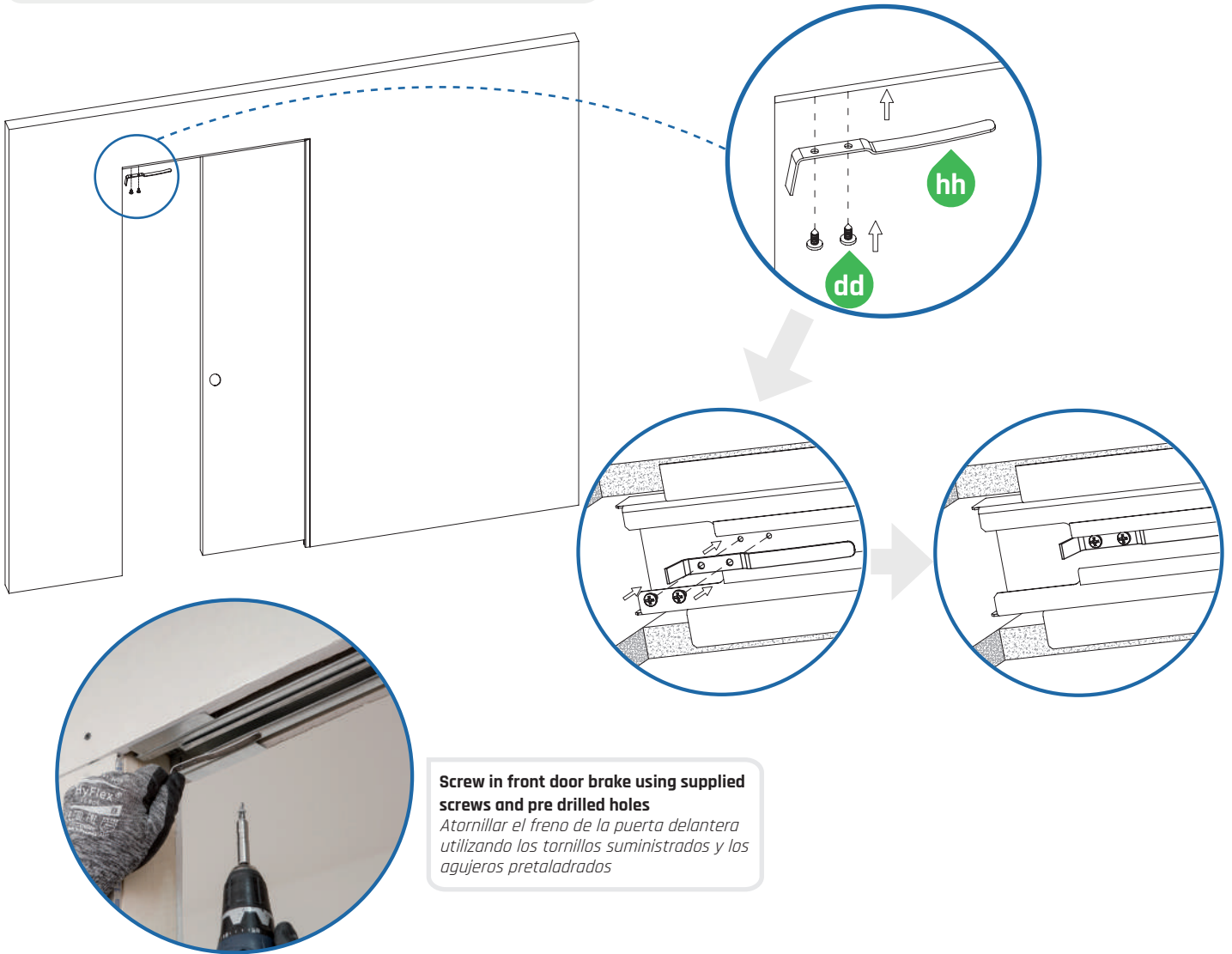

### DOUBLE DOOR PUERTA DOBLE

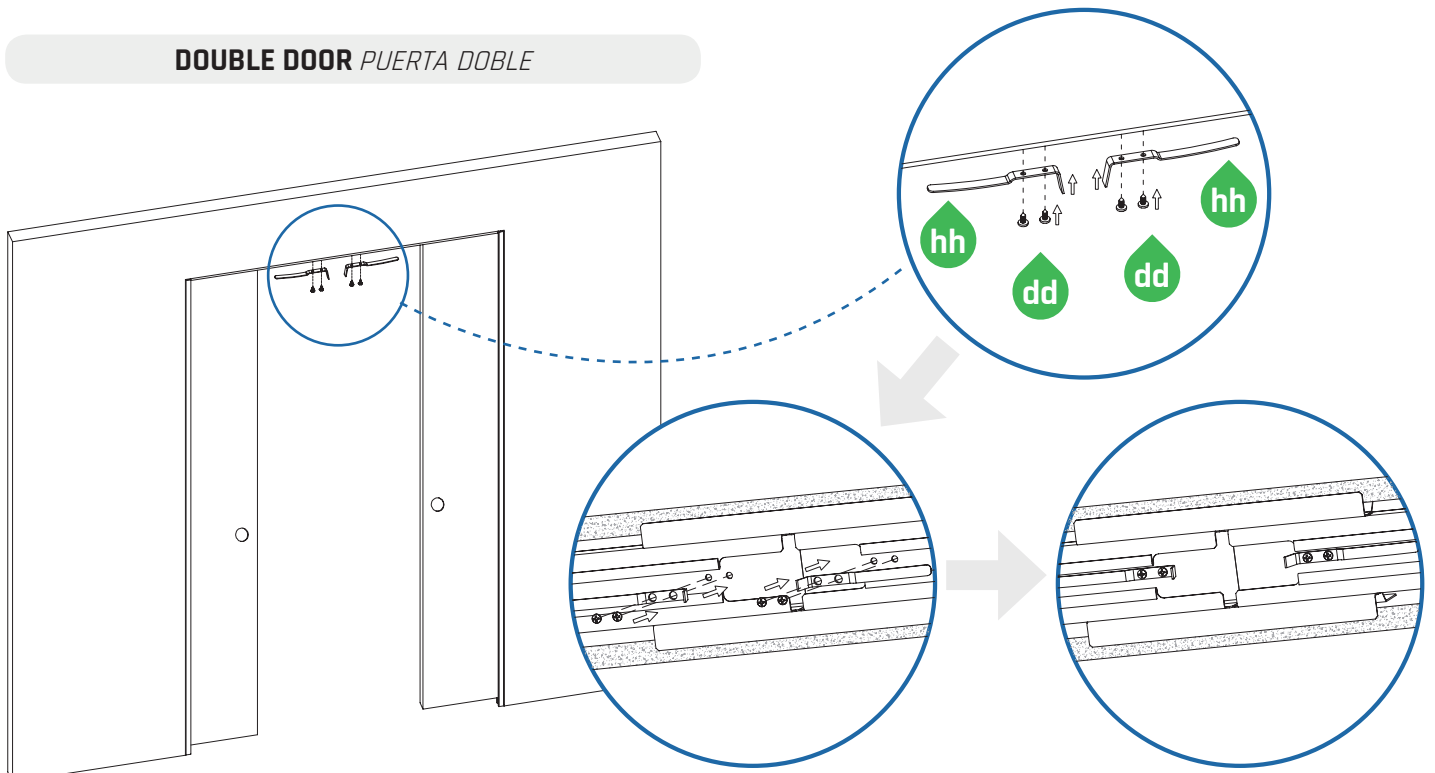





**SEE MORE ON OUR WEBSITE**  
**[WWW.ROCKETDOORFRAMES.COM](http://WWW.ROCKETDOORFRAMES.COM)**